

**!ATTENTION: READ BEFORE ASSEMBLING/OPERATING!**

**ASSEMBLY & PACKING INSTRUCTIONS FOR THE MULTICHAIR 5200 - V.7**

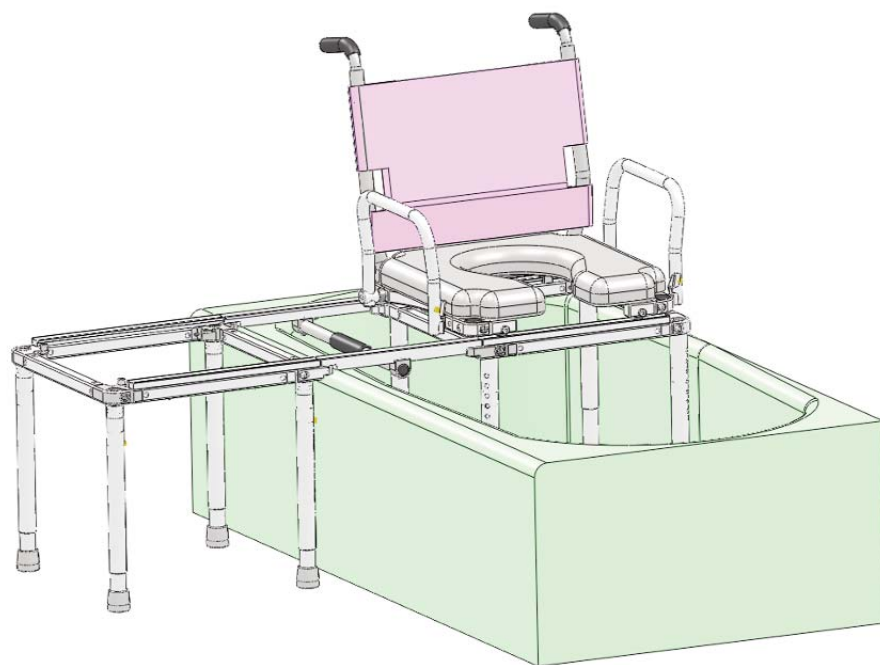

**!ATTENTION: READ BEFORE ASSEMBLING/OPERATING!**

# ASSEMBLY INSTRUCTIONS

## !ATTENTION: PLEASE READ!

Please see Page 6: LIMITED WARRANTY of these instructions. If the warranty is not acceptable, contact Nuprodx, Inc. for information about returning the chair for a refund (Restocking fees and shipping charges will be applied). This chair is designed and intended for indoor shower and bathroom use. It is not designed for outdoor use and will void the warranty if used in this fashion. If thresholds, shower curbs or barriers are encountered that exceed ½" in height, the area in question should be brought within the code for disabled accessibility.

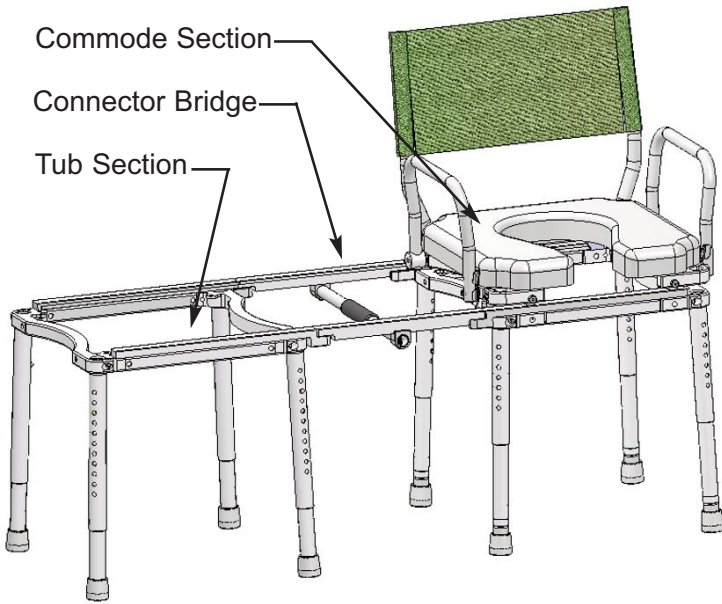

Figure 1

multiCHAIR 5200

**A** The multiCHAIR 5200 (Refer to Figure 1) is composed of three sections: the commode section, the connector bridge section, and the tub section which has straight legs and adjusting feet. The chair is shipped standard with the tub section positioned on the user's left side.

### NOTE!

If you need to position the chair so the tub is on the user's right side, refer to ADDITIONAL ASSEMBLY INSTRUCTIONS (Page 3)

**B** Unpack all parts from the shipping carton. Remove all tape and/or packing from the chair. Keep shipping materials for future use. Note the location of padding materials and sheet-plastic which protects parts of your chair.

**C** Position the frames upside down and install the legs (Refer to Figure 2)

**D** Position the legs so that the brass buttons point outward (Making it easier for future leg height adjustment). Make sure that the legs slide "home" into the socket of the seat frame. Use the included ¼" Allen wrench to securely tighten the bolts located at the corners of the frame (Refer to Figures 2 & 3).

### SAFETY PRECAUTION!

If any of the legs are not fitted correctly into the socket of the seat frame or are not securely tightened there is an extreme risk of the legs dislodging completely from the chair. This could cause serious injury or even death!

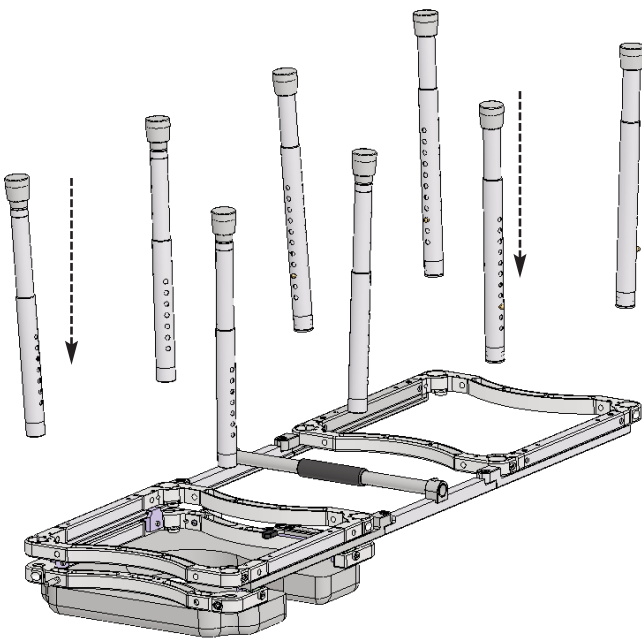

Figure 2

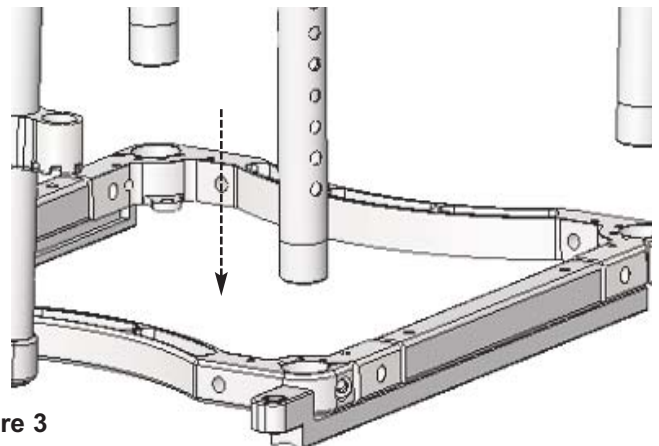

Figure 3

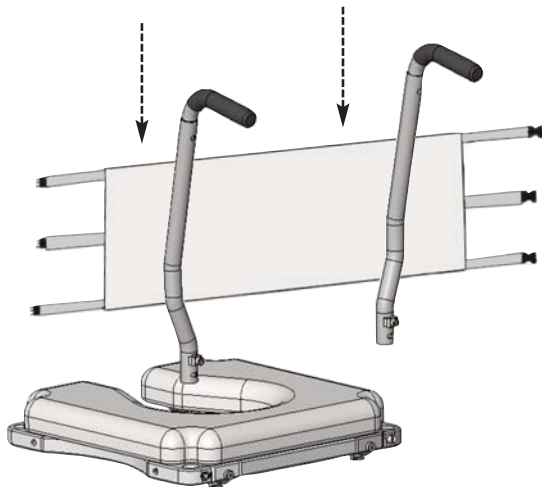

Figure 4

**E Install the backrest assembly:**

- 1) The backrest posts mount to the seat frame and are held in place by pinch clamps and bolts at the rear corners of the seat frame.
- 2) Slide the two backposts into the back of the seat frame and tighten the two socket head cap screws using the 1/4" Allen wrench (Refer to Figure 4).

**SAFETY PRECAUTION!**

Both backrest posts must be completely engaged with the seat frame and securely tightened. If they are not fitted correctly, there is a risk of the posts dislodging from the seat frame. This could cause serious injury or even death!

- 3) Attach the cloth back by wrapping it around the backrest posts, and pressing it against the velcro. Back angle adjustments are possible by changing the length of the straps (Refer to Figure 4).

**SAFETY PRECAUTION!**

Angle adjustments made to the cloth back should never be performed with the user in the chair. Make sure each strap on the cloth back is securely locked before use. Ignoring this safety precaution can cause the cloth back to come loose and possibly separate from the backrest posts, resulting in serious injury or even death!

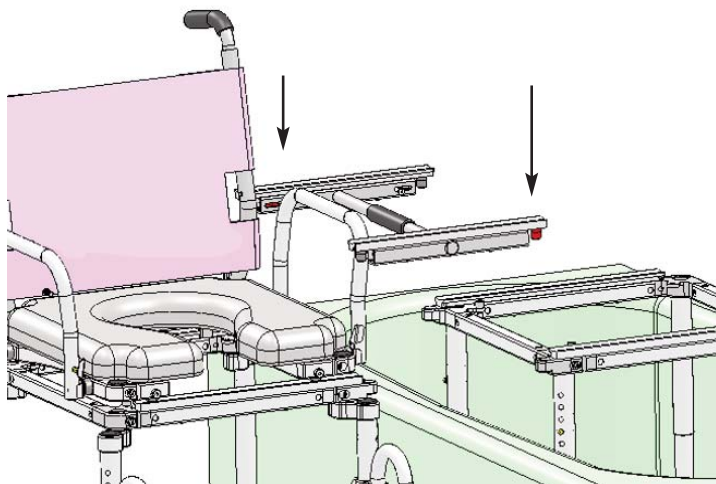

Figure 5

- F Place the connector bridge into the matching holes on both the commode section and tub section (Refer to Figure 5).

**SAFETY PRECAUTION!**

The connector bridge must be fully seated into the corresponding holes of both the roll-in section and tub section. If this is not done correctly, the seat frame could dislodge itself from the chair when transferring from the roll-in section to the tub section. This could cause serious injury or even death!

- G Install the swing-away arms by first slipping the end of the arm with the stainless steel pin into matching holes located in the seat frame. Lower the arms until the latch engages around the black plastic ball attached to either side of the frame (Refer to Figure 6).

**SAFETY PRECAUTION!**

The swing-away arms are not designed to support the entire body weight of the user. Using the arms as a support for transferring into the chair and/or putting extreme amounts of pressure on them could result in damaging the arms and is not recommended.



Figure 6

# ADDITIONAL ASSEMBLY INSTRUCTIONS

## Reconfigure the multiCHAIR 5200 with the Tub Section on the user's right side (Refer to Figure 7):

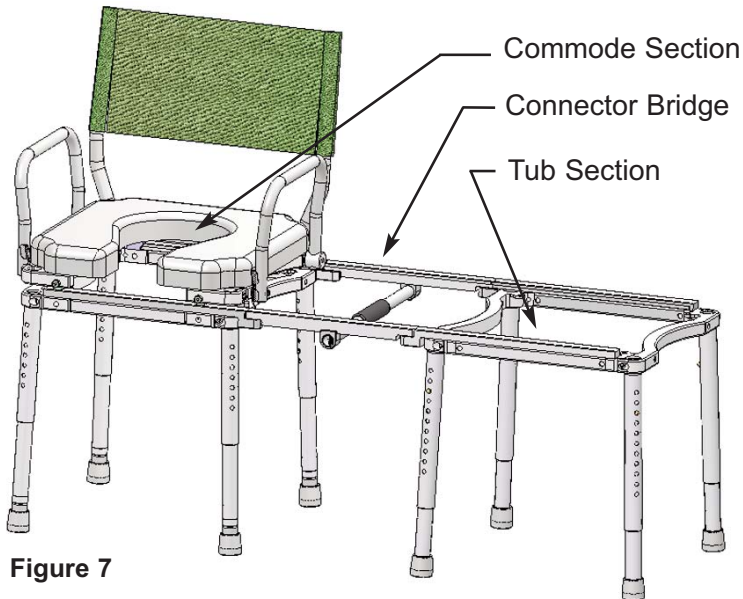

Figure 7

multiCHAIR 5200 - Reversed Orientation

### NOTE!

Assemble the multiCHAIR 5200 to the factory setting (with the tub on the user's left side) first, following the Assembly Instructions (Pages 1-2). Then, if desired, follow the Additional Assembly Instructions to reconfigure the chair with the Tub Section on the user's right side.

- 1) Remove the commode section legs from the frame (Refer to Figure 8)
- 2) Rotate the frame 180 degrees (Refer to Figure 8)
- 3) Re-install the legs (Refer to Figure 8)
- 4) Reverse the release latch: Use the provided black L-Handle wrench to remove the latch by unscrewing the two machine screws, which attach it to the seat frame. Re-install the release latch on the opposite side of the seat frame (Refer to Figure 9).
- 5) Follow the Assembly Instructions (Pages 1-2) to configure the rest of the chair.

### NOTE!

Release Latch Assembly: Do not attempt to unscrew the inner slotted screws. Doing so can cause the entire latch assembly to come apart, rendering it useless (There is no tool provided for this operation) .

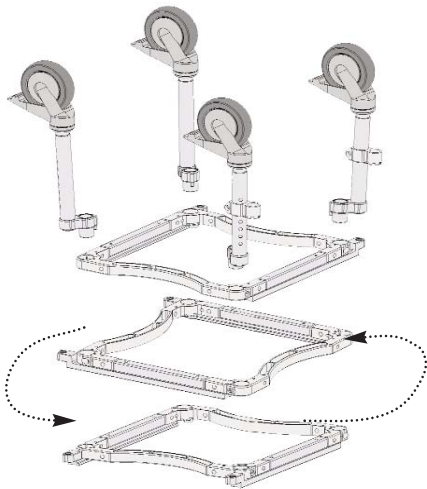

Figure 8

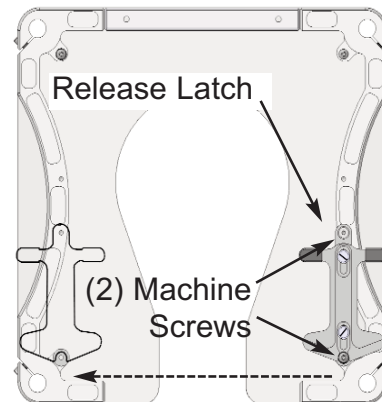

Figure 9

# OPERATING INSTRUCTIONS

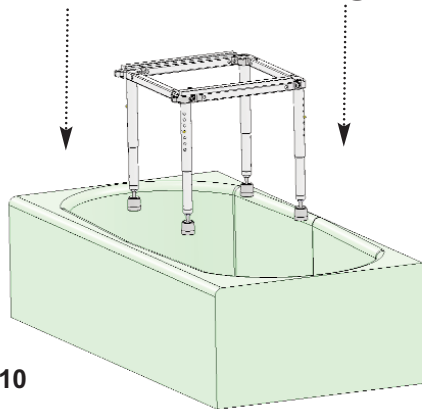

Figure 10

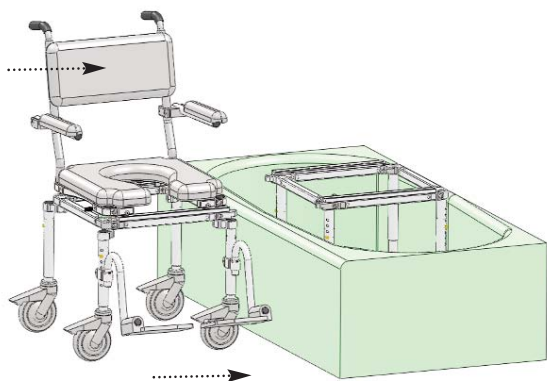

Figure 11

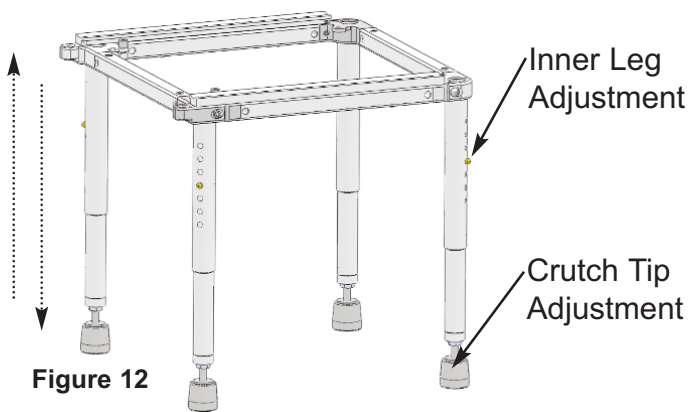

Figure 12

**A** Ensure all fasteners (bolts/washers) are securely tightened and all chair parts have been assembled correctly (Refer back to Assembly Instructions if needed. Contact Nuprodx, Inc. if unsure of anything).

**B** Place the assembled tub section of the slider into the desired position of the bath tub (Refer to Figure 10).

**C** Position the assembled commode section of the slider next to the outside wall of the bath tub (Refer to Figure 11).

**D** Adjust the height of the tub section to match the height of the commode section by either adjusting the four inner legs (tub section) and/or the adjustable crutch tips (tub section) - Refer to Figure 12.

**E** Insert the connector bridge into the four eyelet holes (Two located on the commode section and two located on the tub section) - Refer to Figure 13. Switch the four shoulder screws to the lock position on the connector bridge (Refer to Figure 14).

**F** Release the latch mechanism on the commode section and slide the slider seat assembly onto the tub section, making sure the latch engages fully and locks in place. If the commode section and tub section are not level in height or out of alignment, the slider seat assembly will not function correctly and safely. To ensure the safety of the user, make adjustments to both sections as needed and retry Step F (Refer to Figure 15).

**G** Remove the connector bridge to test the stability of the tub section. Also, ensure that the slider seat frame is locked into place and will not remove during use. Once this is complete, replace the connector bridge and slide the slider seat frame back to the commode section. The connector bridge can then be removed and the chair is ready for use.

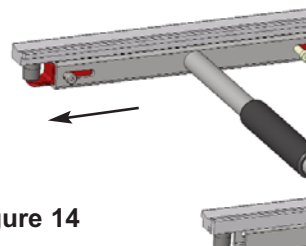

Figure 14

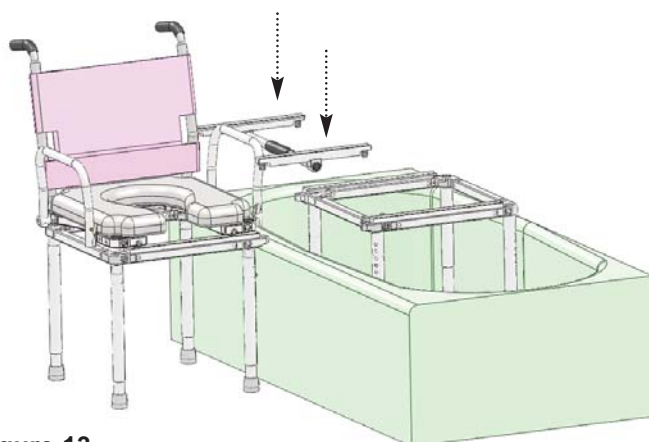

Figure 13

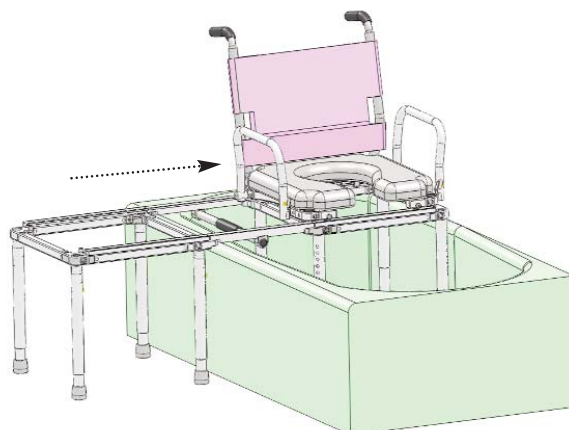

Figure 15

# ADDITIONAL SAFETY PRECAUTIONS

## !ATTENTION: PLEASE READ!

**WARNING!** Failure to account for the aforementioned and the following safety precautions can result in serious injury to the user or even death!

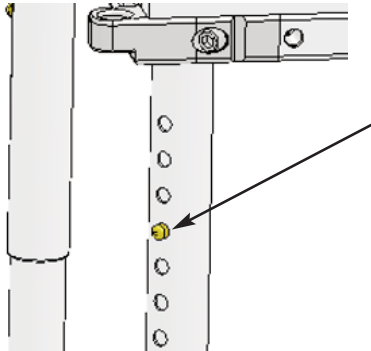

Figure 15

**A Leg Height Adjustment:** When making height adjustments to any of the legs, make sure that the brass buttons are fully engaged into the outer legs. If pushed too hard the button could become stuck inside the inner leg (Contact Nuprodx, Inc. if this occurs). Leg height adjustment should only be made before transferring the user into the chair (Refer to Figure 15).

**B Fasteners:** Over time the screws and washers on the chair may become loose. It is very important that these are checked and securely tightened before each use. Failure to do so could cause a part to dislodge from the chair (Refer to Figure 16).

**C Release Latch:** Verify that the release latch is fully engaged on the slider seat before removing the connector bridge (Refer to Figure 17).

**D Leveling:** The commode and tub sections must both be level and equal in height. To further adjust the height on the tub section legs, rotate the crutch tip feet clockwise or counterclockwise (Refer to Figure 18).

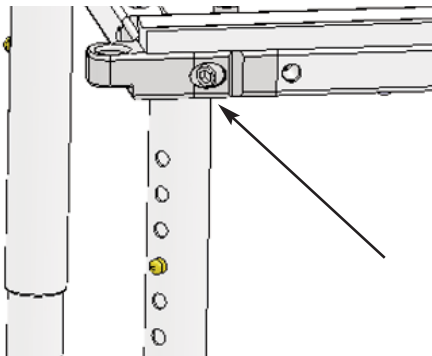

Figure 16

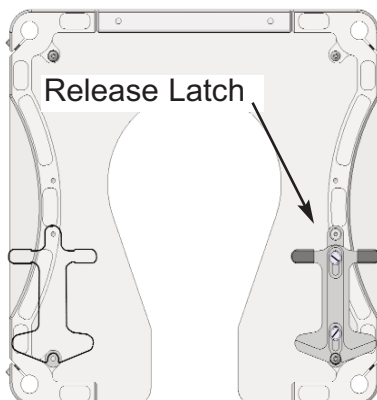

Figure 17

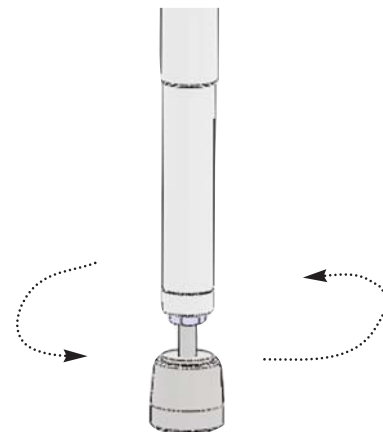

Figure 18

# LIMITED WARRANTY

**A WARRANTY ACTIVATION** Please read this warranty before operating or using your multiCHAIR. To activate the warranty on your multiCHAIR register it online ([www.nuprodx.com/form-registration/index.htm](http://www.nuprodx.com/form-registration/index.htm)) or by phone (888-288-5653). By operating or using the chair, you agree to the terms of this warranty.

**B WARRANTY:** Nuprodx, Inc. warrants this product against defects in material and workmanship as follows: There is a *10-Day conditional money-back warranty*. During this time period, the customer is permitted to try out the multiCHAIR, fully-clothed, keeping the chair in "like new" condition (NOTE: "Like new" condition, in terms of the multiCHAIR, is defined by Nuprodx, Inc. as no visible wear/usage/water marks for the multiCHAIR to be accepted and refunds issued when returned to Nuprodx, Inc.). If the customer decides that the multiCHAIR will not work for them, before the 10-Day period has passed and with the authorization of Nuprodx, the chair can be returned for a full refund minus a *10% restocking charge* (NOTE: The customer is responsible for both in-bound and out-bound freight). After the initial 10-Day period has passed, there is a *two-year limited warranty* for all parts of the chair, with the exception of the seat and back cushions. The seat and back cushions carry a *one year limited warranty*. The warranty does not cover normal "wear and tear" from everyday use of the product and custom parts/custom cushions are also excluded from the warranty and cannot be returned for a refund under any circumstances. Please see section E WARRANTY LIMITATION AND EXCLUSIONS for more info on warranty exclusions.

**C** The warranty period begins on the date you receive the chair. For warranty service, please contact Nuprodx, Inc. no later than one month following the applicable warranty term. The chair will be repaired or replaced at the discretion of Nuprodx, Inc. with no charges to you for parts and labor, provided you have proof of purchase and of purchase date.

**D DISCLAIMER:** Except for the above warranty, and the acknowledgement by Nuprodx, Inc. that the chair, as manufactured by it, is fit for the general purpose for which most persons acquire a chair of its kind, Nuprodx, Inc. provides that you accept the chair as is, without warranties, either express or implied. Nuprodx, Inc. makes no warranty of fitness for your particular purpose and no warranty of merchantability beyond that already stated. No warranties extend beyond the duration of the express warranty stated above.

**E WARRANTY LIMITATIONS AND EXCLUSIONS:** The only obligation of Nuprodx, Inc. is to provide the purchaser with free repair and replacement as described above. This exclusive warranty remedy will not have failed as long as Nuprodx, Inc. is willing and able to repair or replace as described, but if this remedy should be held to have failed, the only remaining warranty obligation of Nuprodx, Inc. shall be to refund the acts beyond the control of Nuprodx, Inc. The warranty does not cover normal "wear and tear" from everyday use of the product. Custom parts/custom cushions are not covered under the warranty.

**F** This warranty gives you specific legal rights, and you may have other rights that may vary from state to state.

**G** This warranty does not apply to problems arising from normal wear, improper operation, improper maintenance, improper storage or similar disclaimer of implied warranties, and some do not allow limitations on how long an implied warranty may last. Some do not allow exclusion or limitation of incidental or consequential damages. So the above limitations or exclusions may not apply to you.

**H RETURN INSTRUCTIONS** In the event that you need to return the Nuprodx multiCHAIR, please follow the instructions below:

- 1) Review the information contained in your warranty to see if this applies to you
- 2) Obtain a Return Authorization # from Nuprodx, Inc. (888-288-5653)
- 3) Re-package the entire chair and its contents in the original packaging and ship to the following address:

Nuprodx, Inc.  
c/o PNM Company  
Attn: RMA# xxxx  
2547 N. Business Park Ave.  
Fresno, CA 93727



4 Malone Lane, San Rafael, CA 94903

(415) 472-1699, (415) 492-1396 fax, (855) 220-5171 toll free, [info@nuprodx.com](mailto:info@nuprodx.com)